

Comparison and analysis of modern combustion powertrain systems of rail vehicles

ARTICLE INFO

Received: 25 May 2023
Revised: 17 August 2023
Accepted: 18 August 2023
Available online: 28 October 2023

The article presents the currently used technologies and solutions for rail vehicle drive systems that can be used in the future. The most popular systems used in locomotives and multiple units are described. In addition, modern solutions such as bi-mode locomotives and hybrid vehicles are shown. The article also discusses the possibility of using ultracapacitors, batteries, or fuel cells in order to increase the efficiency of the powertrain of a rail vehicle. The selection of the appropriate solution depends on the intended use of the vehicle and the assumed traction characteristics and requires a thorough analysis including, among others, modeling of the drive system and its management.

Key words: rail vehicles, combustion engines, powertrains, hybrid, energy storage

This is an open access article under the CC BY license (<http://creativecommons.org/licenses/by/4.0/>)

1. Introduction

Rail transport is one of the important branches of development in the context of the transport of both goods and people. The land connection between Europe and Asia, as well as the convenience of traveling by rail on short and medium-length routes, make the development of rail vehicles an area in which a lot of work is carried out. Still, a large part of the rolling stock owned by Polish carriers are vehicles powered by systems that include internal combustion engines. Figure 1 shows the share of diesel locomotives in all locomotives operated in Poland over the years (2003–2018). It changed over time, but remained constantly at the level of over 50%.

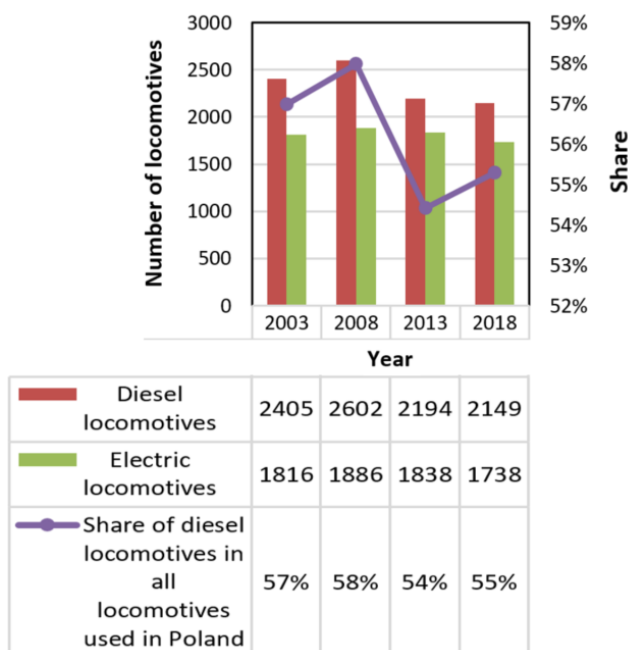

Fig. 1. The structure of the rolling stock in Poland in 2003-2018 [10]

The structure of the rolling stock is closely related to the available infrastructure. Figure 2 shows the distribution of electrified and non-electrified lines on the map of Poland. Lines with different characteristics are adjacent to each other, and non-electrified lines constitute a large part of the Polish railway network, which in 2021 consisted of 19.3 thousand km [3]. Electrified lines have a length of 12.1 thousand km. It should be noted, however, that it is the non-electrified lines that allow the development of transport on a local scale and allow people to move from smaller towns to agglomerations, e.g. to their work or schools.



Fig. 2. Map of Polish electrified (yellow line) and non-electrified (green line) railway lines as of 18.03.2023 [8]

One of the most important factors influencing the development of internal combustion engines in rail vehicles are the successively introduced exhaust emission standards. The latest document on this issue in the context of the NRMM category, which also includes rail vehicles, is the "Regulation of the European Parliament and of the Council (EU) 2016/1628 of September 14, 2016. The regulation introduces subsequent stages determining the maximum

emission values of toxic compounds. The dynamics of changes in the maximum emission values of toxic compounds for stages IIIA, IIIB, and V are presented in Fig. 3. Over the years, more restrictive values have been introduced for the emission of hydrocarbons, nitrogen oxides, and particulate matter.

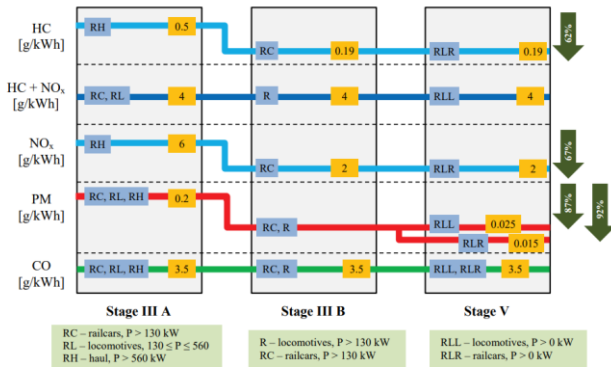

Fig. 3. Change of the permissible maximum emission values of harmful substances for Stage IIIA, IIIB, and V [17]

Rail vehicles, due to the nature of the use of internal combustion engines and the desire to work in stationary conditions, are tested in the NRSC test, and the result is the value of specific emission in g/kWh. The procedure for locomotives and DMUs is in accordance with ISO 8178, type F. In this case, the test determines three operating points covering the entire range of possible loads and engine speeds, to which weighting factors are assigned, determining the impact on the final value of specific emission (Table 1). It should be noted, however, that idling is of the greatest importance, as much as 0.6.

Table 1. ISO 8178, type F exhaust emission measurement test cycle [5]

Mode number	1	2	3	4	5	6	7	8	9	10	11
Torque [%]	100	75	50	25	10	100	75	50	25	10	0
Speed	Rated speed					Intermediate speed					Low idle
Locomotives											
Type F	0.25	-	-	-	-	-	-	0.15	-	-	0.60

2. Diesel locomotives

Diesel locomotives had their heyday in Poland in the times of the People's Republic of Poland. A small degree of electrification was conducive to the development of diesel rolling stock. At that time locomotives popular in Poland, such as: SM42, ST44, SM30, ST43, and SM48 were produced. Characteristic for diesel locomotives is the power transmission system based on an electric gear, where the power on the crankshaft is converted into electricity using the main generator. A diagram showing the construction of a vehicle with such architecture is shown in Fig. 4. Fuel is supplied to the internal combustion engine, then mechanical energy is supplied to the main generator via the shaft. The electric energy is sent through the control element to the electric motor, which drives the wheels of the locomotive wheelset through the transmission. At the same time, some of the electricity on the shaft coming out of the internal combustion engine is used to drive an auxiliary generator

that provides electricity to power the batteries, lights, HVAC, compressors, etc.

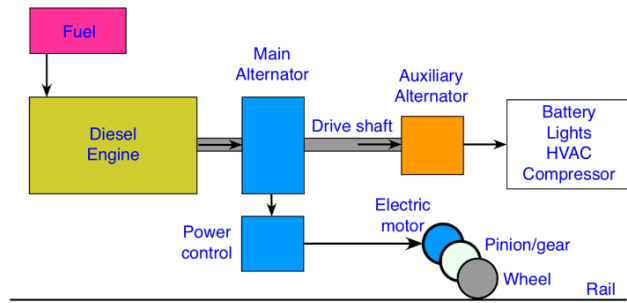

Fig. 4. Diesel locomotive powertrain architecture scheme [24]

New generation engines that meet Stage V requirements must be equipped with an extensive off-engine exhaust aftertreatment system. Due to the degree of its complexity and the amount of space occupied, manufacturers try to create systems that can be adapted to specific customer needs. An example is the modular system offered by MAN (Fig. 5). It has been designed to meet Stage V requirements. The main advantages include the ability to configure the system to match the shape of the system to the designed vehicle and versatility, as one system can be combined with a wide range of engines that are used in different types of non-road vehicles (e.g. forestry, mining or water vehicles). When designing a vehicle or making a retrofit, the possibility of free configuration of the system allows designers to better use the available space, as well as to build the system in a way that facilitates maintenance or repair work. The modular system also allows for easier replacement in the event of damage, thanks to which the time a vehicle is out of service is significantly reduced.



Fig. 5. MAN Modular Exhaust aftertreatment System [16]

3. Diesel multiple units

Due to the need to connect the drive system and passenger space, diesel multiple units are an area of intensive construction work. The development of the drive system in a way that interferes with the areas intended for passengers as little as possible resulted in the separation of two basic types of drive system solutions [6]. These are:

- mounting the engine under the vehicle frame and mechanical connection of the engine with the drive trolley
- using a separate engine compartment with a generator (electric transmission).

Depending on the adopted solution, internal combustion engines with power ranging from 300 to 500 kW are used

for the DMUs. More compact in-line engines (usually six-cylinder) are used, mounted under the floor, or larger engines, even V12, when they are installed in the engine compartment. In connection with the trends in rail vehicles, there is a tendency to build modules that can then be universally used in various vehicles on a plug & play basis. One of the signs of this approach is the creation of Power-pack solutions that integrate the combustion engine with the transmission and other elements of the drive system. An example of such a solution is PowerPack Series 1800 from MTU (technical data shown in Table 2). An important feature of this module is the ability to choose one of three types of gears [23]. The manufacturer allows the ordering party to choose:

- six-speed mechanical transmission with retarder and optional reverse gear
- electric transmission with a permanent magnet synchronous generator or an asynchronous generator
- two-stage hydraulic transmission.

The choice of transmission allows the use of such a module regardless of the adopted vehicle architecture, which is an advantage for both the module manufacturer (reduced technology development costs), the rolling stock manufacturer (possibility of using one solution in many vehicles), and the final recipient (simplified service).

Different versions of the solution are available to meet Stage V requirements. Their power ratings range from 315 to 375 kW at 1800 rpm. The ratio of the cylinder diameter to its stroke is 128/166 mm. The engine has 6 cylinders with a displacement of 2.14 dm³ each, which translates into a displacement of 12.8 dm³. The Stage V aftertreatment system consists of: DOC, DPF, and SCR. MTU's Power-Pack is shown in Fig. 6.

Table 2. MTU PowerPack Series 1800 technical data [23]

Configuration	6H
Rated power	315–375 kW
Rated speed	1800 rpm
Bore/stroke	128 mm/166 mm
Displacement	2.14 dm ³
Displacement, total	12.8 dm ³
Emission qualification	EU Stage V
Exhaust aftertreatment system	DOC, DPF, SCR

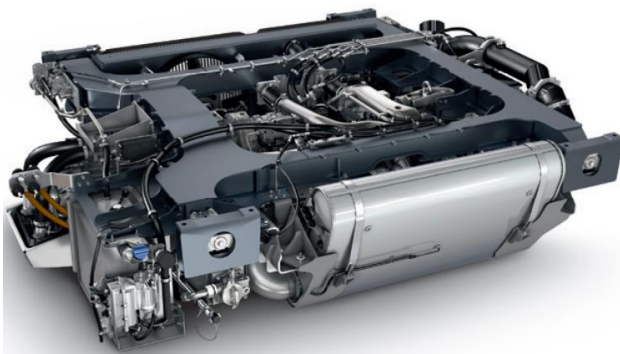

Fig. 6. MTU PowerPack 6H 1800 [23]

4. Hybrid and bi-mode solutions

Due to the development of drive systems used in vehicles in general, modern hybrid drives have also been used

in rail vehicles. Their main task is to increase the efficiency of the system, reduce energy consumption and emissions of harmful substances. This trend is common for all types of non-road machinery. The author of the article [9] states that the development of powertrains faces two major challenges: increasing working parameters and decreased fuel consumption. These two design assumptions are often contradictory to each other and make development more complex. That's why introducing more efficient electrified or hybrid solutions becomes more and more popular. The basic elements of such systems include in the case of locomotives:

- internal combustion engine as the main source of propulsion
- main generator with traction rectifiers
- traction motors cooperating with axial gears
- high-performance battery
- DC/AC power converter and auxiliary converters
- drive control and diagnostics.

It is also worth noting the basic difference between bi-mode and hybrid solutions used in rail vehicles. Due to the presence of electrical systems in the classic solutions of drive systems, these terms are not always interpreted unambiguously, and are often used interchangeably, despite the differences that are easy to identify. It should be noted that a characteristic feature of the hybrid drive is the desire to optimize the operation of the system and achieve the synergy effect. For this purpose, the various drive sources form a single, more complex system. However, they require energy storage. Bi-mode solutions isolate the individual drive sources used, and so, for example, in the case of locomotives, sometimes they work as a diesel locomotive, and sometimes as an electric one (the systems do not interact with each other). Examples of such solutions can be Pesa Gama Dual Power (111DE) or Siemens Vectron Dual Power. Arrangement of devices on the 111DE locomotive is shown in Fig. 7. As the authors of the publication [19] indicate, such a vehicle can be used both in freight and passenger traffic. The advantage is the possibility of smooth travel on electrified and non-electrified lines. Thanks to this, bi-mode solutions fit into the assumptions of intermodal transport. However, they do not allow to manage the flow of energy in the drive because they do not have an element capable of accumulating to the necessary extend.

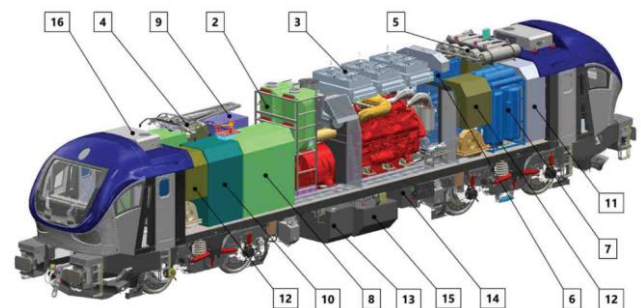

Fig. 7. Arrangement of devices on the 111DE locomotive [19]: 1 – power generator, 2 – set of SCR catalysts, 3 – set of engine coolers, 4 – pantograph, 5 – main air tanks, 6 – compressor module, 7 – panel module, 8 – traction inverter cabinet, 9– cooling column with braking resistor, 10 – high-voltage cabinet 11 – ETCS cabinet, 12 – low voltage cabinet with traction motor fan, 13 – line choke, 14– battery box, 15 – fuel tank, 16 – air conditioner

Due to the characteristics of the drive system and the specificity of the tasks performed, it seems to be particularly advantageous to use hybrid solutions in the DMUs. It is possible to install a parallel hybrid system which shows particular advantages in the conditions of frequent stops and starts, which are an inherent element of regional and agglomeration traffic. In addition, it is possible to use the recuperation of kinetic energy during braking in order to increase the efficiency of the entire system and save energy. A popular system solution in the DMUs is the use of a hybrid PowerPack. An example of such a device may be the 1800 Series from MTU. The module consists of an internal combustion engine, a gearbox with an electric motor (parallel hybrid), a set of batteries, a cooling system, and an exhaust system. The Hybrid PowerPack 6H 1800 is shown in Fig. 8, while an example of the installation on a rail vehicle is shown in Fig. 9. It should be noted that the design assumes the use of only a mechanical transmission, excluding the use of a system with an electric transmission. The PowerPack must, therefore be mounted under the floor of the vehicle, whereby the batteries can be attached to the roof or under the floor due to the electrical connection. Mounting on the roof allows for a larger area of the low floor and saves space for the installation of other devices that should be placed under the vehicle frame. In addition, it is easier to solve the issue of cooling the batteries, which is also of great importance.

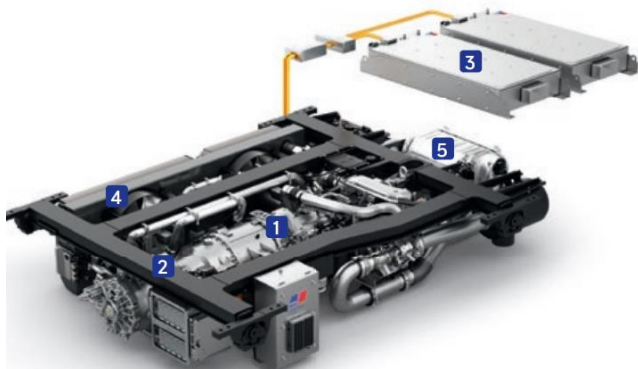

Fig. 8. MTU Hybrid PowerPack 6H 1800 structure [23]: 1 – engine, 2 – power transmission, 3 – battery system, 4 – cooling system, 5 – exhaust system

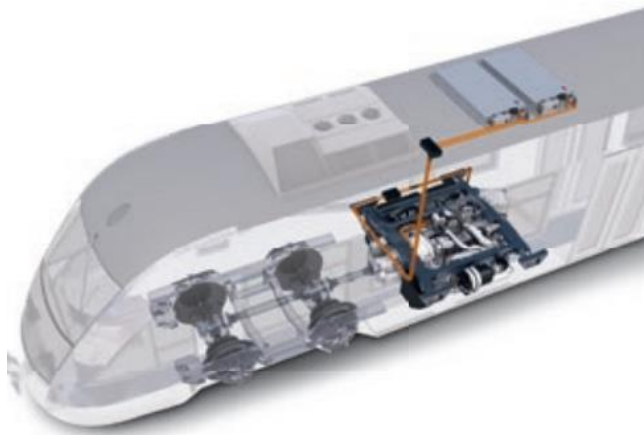

Fig. 9. MTU Hybrid PowerPack 6H 1800 installation [23]

The parameters of the device are presented in Table 3. Depending on the selected version, the combustion engine power is 315 or 375 kW at a rotational speed of 1800 rpm. The ratio of the bore to stroke is 128 to 166 mm. The engine has a 6-cylinder with an in-line configuration, and each cylinder has a displacement of 2.14 dm³, which translates into a displacement of 12.8 dm³. It is adapted to meet the requirements of Stage V. Thanks to the use of a hybrid system, the PowerPack has the possibility of energy recuperation, boost mode, and the ability to drive only using the 142 kW electric motor. MTU combines its hybrid PowerPack solutions with battery modules with a capacity of 34.4 kWh. The number of modules can be selected individually for each designed vehicle. The exhaust system is equipped with DOC, DPF, and SCR to meet Stage 5 requirements. The operation of the system is supervised by an intelligent automation system used to optimize its operation. Technical data of the PowerPack are shown in Table 3.

Table 3. MTU Hybrid PowerPack 6H 1800 technical data [23]

Combustion engine types	
6H 1800 R76	315 kW
6H 1800 R86	375 kW
Speed	1800 rpm
Bore/stroke	128 mm/166 mm
Cylinder configuration	6/in line
Displacement	2.14 dm ³
Displacement, total	12.8 dm ³
Emission qualification	Stage V
Standard equipment	
E-Drive	For recuperating, boosting and pure electric drive; 142 kW
Energy storage	Li-Ion batteries incl. battery management system and conditioning system. Underfloor or roof installation. 34.4 kWh per battery module
Transmission	Mechanical gearbox with integrated reversing function/Mechanical gearbox without integrated reversing function
Cooling system	Integrated in PowerPack, electrically driven
Exhaust gas aftertreatment system	EU Stage V, aftertreatment combi system with DOC, DPF and SCR; reducing agent injection with supplying and dosing unit
IDM (Intelligent Drive Manager)	Smart automation system to optimize the operation of the Hybrid PowerPack based on GPS and track data
On-board power supply	3P~AC, 400 V/50 Hz; up to 70 kVA

The choice of a bi-mode or hybrid solution should be preceded by a broad recognition of needs, a series of simulations and comparisons. Power demand should be determined based on traction characteristics and potential gains and losses. Both financial and energy terms should be determined. Due to the above, the creation of an appropriate drive system is a difficult process that requires experience, but also multi-criteria optimization. Modeling the fuel consumption and energy flow is a demanding study. Article [15] shows the mathematical model demonstrating the synergy of HEV. It also shows different types of energy management systems. For example, they can be based on:

heuristic hypotheses, statistical optimisation, stochastic-dynamic programming, algorithms of the equivalent fuel consumption strategy, and particle swarm optimisation. Variety of available approaches is another challenge as modeling every type makes it necessary to perform many characteristics and assumptions. Preparing models for different architectures requires a lot of resources for the research and development phase, increasing the price of the vehicle design. Moreover, the negative influence of a vehicle life cycle can be reduced using new types of oxygenated fuels, reducing emissions of PM and NO_x [11, 12].

One of the important aspects of hybrid drives is the energy storage system. Its selection should be preceded by a thorough analysis of its usefulness in a given vehicle on the basis of its traction characteristics, but also the nature of work or route profiles. Choosing the right solution is not easy, and it can help, for example, by optimization, which helps to quantitatively select the best solution in given conditions and under certain boundary conditions. When selecting an energy storage element in a hybrid system, its operational parameters should be considered, such as:

- mass
- efficiency
- energy density
- power density
- lifetime.

However, it is also worth considering aspects related to the production and recycling of the energy storage system. In order to evaluate the solutions, the following can be compared:

- energy consumption of production and recycling
- production and recycling emissions
- resources needed for production
- recyclable.

One of the most popular technology decades ago, and at the same time the simplest ways to store energy is the use of flywheels and thus the storage of mechanical (kinetic) energy. In this way, energy can be easily stored, provided that it is used in a short time. However, this technology is mainly used in bus projects.

Currently, the most popular way to store energy is the use of batteries, i.e. the use of electrochemical energy. Primarily, lithium-ion batteries are used, which are currently popular in all areas of life.

Saft company offers a battery system of various capacities, which consists of blocks of cells connected in sets of 108, 180 or 360 cells. Thanks to this, the capacities of 7.5, 12.5, and 25 kWh are achieved, respectively. Technical data of a single cell are shown in Table 4.

Li-ion batteries disadvantage is safety and average power density. In addition, there are significant fluctuations between their capacity depending on the temperature. This presents scientists with the challenge of developing a technology that will allow the creation of electrochemical batteries with a higher power and energy density, and at the same time ensure safe and durable use. A partial answer to these needs is the development of solid electrolyte battery technology. Replacing the electrolyte in a liquid state with a solid substance allows for several advantages. The level of safety is increased because there is no risk of fire or

explosion. The energy density is higher compared to lithium-ion batteries [25]. This technology also creates the possibility of using cathodes from new materials due to the greater potential of anodes with a solid electrolyte. For this reason, that technology is considered to be the future of energy storage development in vehicle drives. Solid electrolytes can be divided into: polymeric, inorganic, and composite materials. However, before it can be disseminated on a large scale, scientists need to solve the problems arising from the use of solid electrolytes related to the electrochemical properties of the electrolyte. Comparison of Li-Ion and solid state battery schemes is shown in Fig. 10. Moreover nanocomposites and hybrids are used for Li-Ion batteries to achieve new, improved characteristics [13].

Table 4. Saft LP 28MTi Li-ion power cell technical data [20]

Nominal characteristics at +25°C	
Nominal voltage [V]	2.25
Energy [Wh]	63
Gravimetric energy [Wh/kg]	78
Mechanical characteristics	
Width [mm]	148
Height [mm]	101.7
Depth [mm]	26.5
Weight [g]	810
Cell typical operating conditions at +25°C	
Typical cut off voltage [V]	1.6
Charging method	Constant current Constant voltage
Charging voltage [V]	2.7 ±0.05
Maximum continuous charge/discharge current [A]	280
Maximum pulse charge/discharge current 30 s [A]	450
Cycling performances	20 000 cycles (80% DOD) 1.6 mil cycles (3% DOD)

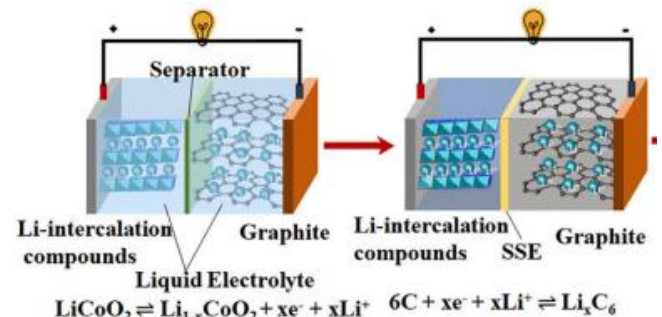

Fig. 10. Comparative diagram of Li-ion battery (left) and solid-state battery (right) [25]

Another concept is to use electricity directly through the use of ultracapacitors. No chemical reaction takes place in them, which allows for durability. In addition, they allow for quick loading and unloading. The development possibilities of increasing the capacitance of capacitors are limited only by the possibility of obtaining larger surfaces of their electrodes and reducing the distance between them. Supercapacitors can be divided into [14]:

- Pseudocapacitors or Redox Capacitors
- Electric double layer capacitors (EDLCs)
- Hybrid capacitors.

The most important quantity characterizing supercapacitors is specific capacitance, which defines the capacitance

per unit mass. The value depends on the material used, but the creation method also has an impact.

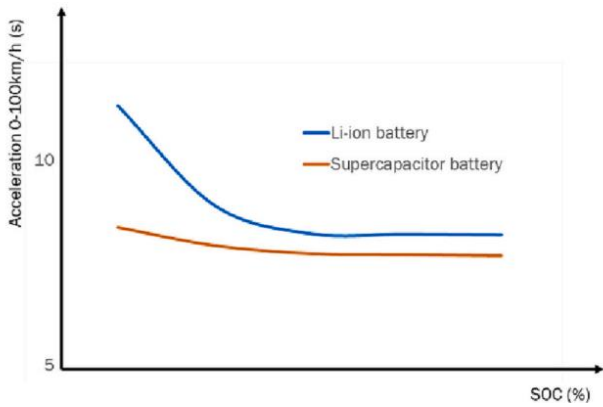

Fig. 11. HEV acceleration 0–100 km/h [7]

When it comes to technology performance, supercapacitors show great stability in the power output compared to the li-ion battery. Figure 11 shows the comparison of acceleration of a vehicle powered by these power sources. Decreasing SOC has a significant influence on electrochemical battery power and therefore acceleration time increases. It can be assumed that that supercapacitor can be used in a wider range of SOC without compromising the vehicles performance.

Figure 12 shows a comparison of the energy density and power density of various energy storage devices. Supercapacitors and li-ion batteries have a similar range of energy density but the power density is higher in supercapacitors. Fuel cells have high energy densities and low power densities. however, they are becoming more and more popular due to the possibility of creating zero-emission energy using hydrogen. It’s one of the possible ways to achieve climate neutrality

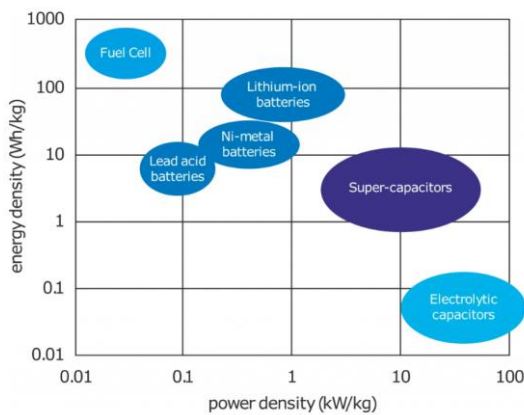

Fig. 12. Ragone plot of energy density vs power density of various energy storage devices including supercapacitors [26]

Hydrogen fuel cells have a number of advantages, the most important of which are a simple principle of operation negligible emission of harmful substances, and relatively large values of efficiency [4]. The electrical efficiency of a typical cell is in the range of 40–60%, and the total effi-

ciency can reach 80–90% during electricity generation. Key factor that needs to be considered is the production of hydrogen. There’s a variety of different methods and “brown” and “green” hydrogen can be separated [21]. Green methods are sustainable and these can be:

- Electrolysis of water using renewable power
- Steam methane reforming with carbon capture and storage techniques
- Gasification of biomass and biogas to produce syngas
- Fermentation of biowastes to produce H₂, CO, CO₂.

Brown methods, on the other hand are considered to be unsustainable and these can be:

- Steam methane reforming
- Coal gasification
- Oil partial oxidation.

Apart from hydrogen production, also its storage is a widely developed issue. The most popular architecture uses 35 MPa compressed hydrogen [2]. This technology offers good storage capacity at a low cost for regional passenger transport. Unfortunately, there’s no technology in sight enabling to reach higher energy densities required for ensuring the constant high-power demand of a mainline locomotive.

In the cells, only a chemical reaction of hydrogen with oxygen takes place:



The first rail vehicle using hydrogen fuel cells is the Coradia iLint manufactured by Alstom.

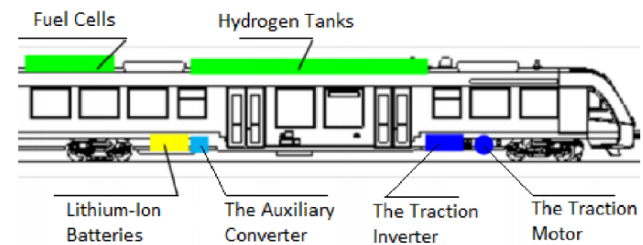

Fig. 13. Scheme of the Coradia iLint powertrain [22]

The construction of the vehicle is relatively simple (Fig. 13). Two compressed hydrogen (35 MPa) tanks and PEM fuel cells [18] are located on the roof of the vehicle. A lithium-ion battery that can store excess energy generated by the fuel cell has been placed under the floor of the vehicle. An auxiliary generator has been installed next to it, which provides power for devices such as sliding doors, HVAC, etc. Traction converters and traction motors are located near the drive trolleys. The presented vehicle does not have a combustion engine, but it is possible to use hybrid vehicles combining combustion and hydrogen drive as an intermediate link on the way to complete zero-emissions. Such a vehicle could support non-electrified traction. Authors of [21] state that hydrogen powered vehicles should be considered when long-term technical, environmental and/or economic factors make electrification a poor option. Table 5 shows technical data of a Ballard’s FCmove™-XD fuel cell (Fig. 14). System power reaches 100 kW with a wide range of operating current and voltage.

Table 5. Ballard FCmoveXD fuel cell technical data [1]

Net system power [kW]	100 (± 2)	
Operating system current [A]	20–360	
Operating system voltage [V]	280–560	
Dimension L \times W \times H [mm]	Roof Top	1714 \times 812 \times 360 (excluding air filter)
	Engine Bay	1240 \times 572 \times 702 (excluding air filter)
Dry weight [kg]	275	
Environmental protection	IP67	
Start-up temperature [$^{\circ}$ C]	–25	
Environmental operating temperature [$^{\circ}$ C]	(–30)–(+50)	
Short-term storage temperature [$^{\circ}$ C]	(–40)–(+80)	
Peak efficiency [%]	57	
Idle power [kW]	9	
Nominal radiator coolant outlet temperature [$^{\circ}$ C]	70	



Fig. 14 Ballard FCmoveXD fuel cell [1]

5. Conclusions

Rail vehicles powered by powertrains containing internal combustion engines remain an important part of

transport in Poland. The level of electrification of the networks means that they will be used for many years to come. Design changes related to the development of drive systems for diesel locomotives and DMUs include mainly the development of exhaust gas aftertreatment systems. New possibilities are provided by the hybridization of systems and the creation of bi-mode vehicles. Bi-mode locomotives can be used for intermodal transport. Diesel multiple units can be equipped with hybrid powerpacks. Creating a hybrid vehicle requires the installation of an energy storage system. It can be a li-ion battery, a supercapacitor, or a fuel cell. Each of these methods is being developed. Work is being carried out on batteries with solid state electrolyte and materials for supercapacitors, which will ensure their high capacity. Fuel cells also have been dynamically developing for years, thanks to which they can successfully power vehicles, including rail vehicles such as shown the Coradia iLint translation.

Comparison of the weight and dimensions of a fuel cell and an MTU 6R 1300 engine shows that power per unit mass and per unit volume are similar (Table 6). That comparison shows that a modern fuel cell can be competitive when it comes to replacing combustion engines on non-electrified lines. Another technical problem is the storage of hydrogen used to power the fuel cell. Mounting hydrogen tanks takes a valuable place that is very much needed during designing a rail vehicle. Many devices used in vehicles are necessary for securing high level of passengers comfort but also to provide safety in rail transport. Because of that, it's not an easy task to find more space to mount hydrogen tanks. This can lead to a small range of a vehicle.

Table 6. Comparison of Ballard FCmoveXD fuel cell and MTU 6R 1300 C diesel engine [1, 23]

	FCmove-XD	MTU 6R 1300 C 20	MTU 6R 1300 C 60
Weight	275 kg	1140 kg	1140 kg
Power	100 kW	320 kW	390 kW
Volume	0.5 dm ³	1.7 dm ³	1.7 dm ³
Power to volume ratio	200 kW/dm ³	188 kW/dm ³	230 kW/dm ³
Power to mass ratio	0.36 kW/kg	0.28 kW/kg	0.34 kW/kg

There's no possibility to choose one powertrain architecture that suits all of the vehicles and their scope of work. Exact analysis is needed including modelling of the powertrain and its management. This leads to a variety of solutions offered by rolling stock producers.

Nomenclature

AC	alternating current
DC	direct current
DMU	diesel multiple unit
DOC	diesel oxidation catalyst
DPF	diesel particle filter
HVAC	heating, ventilation, air conditioning
ISO	Organization for Standardization

NO _x	oxide
NRMM	non-road mobile machinery
NRSC	non-road steady cycle
PEM	proton exchange membrane
PM	particulate matter
SCR	selective catalytic reduction
SOC	state of charge

Bibliography

- [1] Ballard FCmove HD+ data sheet, Ballard. <https://www.ballard.com> (accessed on 05.2023).
- [2] Böhm M, Fernández Del Rey A, Pagenkopf J, Varela M, Herwartz-Polster S, Nieto Calderon B. Review and comparison of worldwide hydrogen activities in the rail sector with special focus on on-board storage and refueling technologies. *Int J Hydrogen Energy*. 2022;47(89):38003-38017. <https://doi.org/10.1016/j.ijhydene.2022.08.279>
- [3] Concise Statistical Yearbook of Poland 2022. Warsaw 2022.
- [4] Daszkiewicz P, Kurc B, Pięłowska M, Andrzejewski M. Fuel cells based on natural polysaccharides for rail vehicle application. *Energies*. 2021;14:1144. <https://doi.org/10.3390/en14041144>
- [5] DieselNet. Engine & emission technology online – since 1997. <https://dieselnet.com> (accessed on 05.2023).
- [6] Far M. Study of new solutions for drive and control systems for light rail vehicles (in Polish). Poznań 2021.
- [7] Guo L, Hu P, Wei H. Development of supercapacitor hybrid electric vehicle. *Journal of Energy Storage*. 2023; 65:107269. <https://doi.org/10.1016/j.est.2023.107269>
- [8] Interactive Map of Railway Lines – <http://mapa.plk-sa.pl> (accessed on 05.2023).
- [9] Kalociński T. Modern trends in development of alternative powertrain systems for non-road machinery. *Combustion Engines*. 2022;188(1):42-54. <https://doi.org/10.19206/CE-141358>
- [10] Kamińska M, Kołodziejek D, Szymlet N, Fuć P, Grzeszczyk R. Measurement of rail vehicles exhaust emissions. *Combustion Engines*. 2022;189(2):10-17. <https://doi.org/10.19206/CE-142526>
- [11] Kozak M, Merkisz J, Bielaczyc P, Szczotka A. The influence of oxygenated diesel fuels on a diesel vehicle PM/NO_x emission trade-off. *SAE Technical Paper 2009-01-2696*. 2009. <https://doi.org/10.4271/2009-01-2696>
- [12] Kozak M, Merkisz J. Oxygenated diesel fuels and their effect on PM emissions. *Applied Sciences*. 2022;12:7709. <https://doi.org/10.3390/app12157709>
- [13] Kurc B, Pięłowska M, Rymaniak Ł, Fuć P. Modern nanocomposites and hybrids as electrode materials used in energy carriers. *Nanomaterials*. 2021;11:538. <https://doi.org/10.3390/nano11020538>
- [14] Lamba P, Singh P, Singh P, Singh P, Bharti, Kumar A et al. Recent advancements in supercapacitors based on different electrode materials: classifications, synthesis methods and comparative performance. *Journal of Energy Storage*. 2022;48:103871. <https://doi.org/10.1016/j.est.2021.103871>
- [15] Lisowski M, Gołębiowski W, Prajwowski K, Danilecki K, Radwan M. Modeling the fuel consumption by a HEV vehicle – a case study. *Combustion Engines*. 2023;193(2):71-83. <https://doi.org/10.19206/CE-157112>
- [16] MAN Truck & Bus. <https://www.mantruckandbus.com> (accessed on 05.2023).
- [17] Merkisz J, Pielecha I, Andrzejewski M, Daszkiewicz P, Stawecki W. Legal conditions in the aspect of pollutant emissions from exhaust systems of rail vehicles engines. *Journal of KONES*. 2018;25(1):257-264. <https://doi.org/10.5604/01.3001.0012.2475>
- [18] Pielecha I, Dimitrov R, Mihaylov V. Energy flow analysis based on a simulated drive of a hybrid locomotive powered by fuel cells. *Rail Vehicles/Pojazdy Szynowe*. 2022;(1-2):68-76. <https://doi.org/10.53502/RAIL-152703>
- [19] Pietrzekiewicz H, Domagała R, Michalak P. Application of locomotive dual mode type 111DE for intermodal transport. *Research and Technical Papers of Polish Association for Transportation Engineers in Cracow. Series: Proceedings*. 2021;2(123):305-314.
- [20] Saft LP 28MTi Rechargeable LTO PHEV-2 cell data sheet, Saft, 22024-1019-2, 2019.
- [21] Shirres D, Baxter J. The future for hydrogen trains in the UK. 2019. <https://www.imeche.org/policy-and-press/reports/detail/the-future-for-hydrogen-trains-in-the-uk> (accessed on 06.2023)
- [22] Siwiec J. Application of hydrogen fuel cells in railway transport. *Railway Reports*. 2021;190:53-57. <https://doi.org/10.36137/1906P>
- [23] Sustainable power that matters. <https://www.mtu-solutions.com> (accessed on 05.2023).
- [24] The Railway Technical Website. http://www.railway-technical.com/_Media/diesel-loco-block-diagram_m_med_hr.png (accessed on 05.2023).
- [25] Xia S, Wu X, Zhang Z, Cui Y, Liu W. Practical challenges and future perspectives of all-solid-state lithium-metal batteries. *Chem*. 2019;5(4):753-785. <https://doi.org/10.1016/j.chempr.2018.11.013>
- [26] Zurich Instruments. <https://www.zhinst.com/europe/en/blogs/using-mfia-impedance-analyzer-characterize-esr-super-capacitor> (accessed on 05.2023).

Paweł Daszkiewicz, DEng. – Faculty of Civil and Transport Engineering, Poznań University of Technology, Poland.
e-mail: pawel.daszkiewicz@put.poznan.pl



Daniel Kołodziejek, MEng. – Institute of Railway Transportation, Poznań, Poland.
e-mail: daniel.kolodziejek@itstech.pl

