

Concept and design of the transport cover for the harvesting unit of a self-propelled forage harvester

ARTICLE INFO

Received: 6 November 2025
Revised: 2 January 2026
Accepted: 26 January 2026
Available online: 19 February 2026

This paper presents a conceptual model of a transport cover for a grain maize harvesting attachment. To develop a model of the cover structure, a dimensional base in the form of a harvesting unit was required, to which the designed transport cover was referred. The existing Dominoni SL 978 harvest unit was used as a dimensional base, and a model of the design base was created, accounting for the most important dimensions. The conceptual model was adapted to the design base, taking into account the design assumptions, resulting in a model of a transport cover. To mount the cover to the attachment, a dedicated hooking system has been designed.

Key words: *transport cover, harvesting unit, self-propelled forage harvester, design*

1. Introduction

Agriculture and the food industry are among the fundamental sectors of the economy. This results in a large volume of agricultural goods, as well as work performed with appropriate machinery and equipment [18]. Although the equipment of farms with agricultural machinery depends on the type of agricultural production [16], the basic self-propelled vehicle is the combine harvester [13, 23, 30]. This is an agricultural machine used for harvesting grains [4], such as wheat [24], corn, barley, or rice [1, 7, 8, 15].

Combine harvesters with an axial threshing and separating device, after improvements to the axial drum design, are increasingly used for harvesting other cereals [31]. It is characterized by specially designed components that enable efficient and rapid harvesting [12, 26], separation of grain from chaff [22], and transport and storage of harvested grain. Combine harvesters are equipped with various types of centrifuges, sieves, sifters, and other mechanisms for precise separation of grains and removal of plant residues. They can also be equipped with systems for cutting and chopping straw and attachments for harvesting corn intended for grain [34]. The primary power source for combine harvesters is combustion engines (NRMM (Non-Road Mobile Machinery) engines). Among all off-road engines, these vehicles' engines operate under specific conditions [2, 3]. Despite intensive work on the development of alternative drive systems [28, 33], combustion engines will likely remain the main power source for self-propelled vehicles, tractors, and agricultural machinery for many years to come [19], including combine harvesters, also as units cooperating with generators in hybrid drive systems [20].

Due to their large dimensions and weight, combine harvesters may require special transport on public roads. Depending on the additional equipment, transporting such a machine may require the use of additional safety devices, such as safety guards. In this context, transporting a combine harvester with a corn header requires compliance with applicable road regulations.

Research on the safety of agricultural machinery in road traffic is therefore crucial to protecting both road users and agricultural machinery operators [32]. Numerous reports

and scientific studies on this topic analyze the risks posed by the movement of agricultural machinery on roads and propose countermeasures and recommendations to improve safety. The results of these studies often emphasize the need to increase passenger car drivers' awareness of the presence of agricultural machinery on roads, improve the visibility of agricultural machinery through the use of appropriate markings, lighting, and guards, and introduce regulations governing the safe behavior of both machinery operators and drivers of other vehicles.

Conducting research in this area is crucial for continuously improving the safety of agricultural machinery in road traffic and for reducing accidents involving it. Transport safety is crucial to protecting people, property, and the environment. Therefore, implementing appropriate mechanical engineering solutions is key to improving road transport safety. Thanks to modern technologies and engineering solutions, it is possible to provide more resilient and safer means of transport and transport infrastructure, including through the use of appropriate safeguards.

This article presents research focused on improving the safety of agricultural equipment transport (corn harvester attachments). Collaboration among engineers, manufacturers, transport and forwarding operators, and regulatory institutions led to the development of a safety guard solution that increased safety and efficiency in agricultural transport. The article was written within the framework of engineering and technical sciences and addresses issues related to the design, research, production, operation, and safety of transport means and methods, which align with the journal's thematic scope.

Agricultural tractors, slow-moving vehicles (e.g. combine harvesters) and vehicle combinations consisting of an agricultural tractor or a slow-moving vehicle and a special trailer (e.g. a combine harvester with a trolley attached to the transport of a harvesting unit) are strictly subject to the provisions of the Road Traffic Act and the Act "Technical conditions of vehicles and the scope of their necessary equipment". This means that these vehicles must not be wider than 3 meters when moving on public roads [36]. If the vehicle or combination of vehicles exceeds 3 meters in

width but does not exceed 3.5 meters, the driver may be able to apply for a category I permit, which authorizes the driver to drive on public roads as a non-standard vehicle [37].

Therefore, the aforementioned legal regulations exclude the vast majority of combine harvesters with a harvesting unit from driving on public roads. The width of these complexes usually exceeds 4 meters (only a few older structures have units 2 to 3.5 meters wide) [36, 37].

The situation is slightly different for foldable harvesting units, whose transport width does not exceed 3.5 meters. Hence, especially for maize harvesting for silage and grain, folded harvesting units have been developed in recent years [5, 17].

For self-propelled forage harvesters and maize silage harvesters, solutions exist to increase road safety; for manufacturers of folding harvesting units, however, it is difficult to find transport guards that increase safety.

In the context of the above, the concept of a special transport cover for the attachment (header) for combine harvesters intended for harvesting grain maize was undertaken, which is presented in this publication. A lightweight, simple structure, ease of installation, and ease of use characterize the developed solution. The designed cover meets all the requirements of the traffic regulations for vehicle protection systems on public roads.

2. Transport security – an overview of dedicated solutions





2.1. Transport protection of shearing units of self-propelled forage harvesters

Transport guards, called transport protections by some manufacturers, are most often automatic opening and closing, and their task is to shield the outside complex shear units, which contain sharp working elements that primarily pose a threat to pedestrians, cyclists, and other road users not protected by the vehicle body [5, 11, 25, 29].

Table 1 provides a brief overview of the existing protection solutions used by leading manufacturers of forage harvesters.

To sum up, it can be said that transport guards are standard on manufacturers' self-propelled forage harvesters and maize silage harvesters. Technological advancement means that the machine operator does not have to leave the cab to fold or disassemble the cover. Manufacturers use two solutions for connecting the cover to the machine's structure or its harvesting unit: transport covers, which are developed as an integral part of the device [38, 39], or structures dismantled during work (harvesting plants) [40]. The advantage of the latter solution is that when working in the field, the forage harvester is not burdened with additional cover weight. Among the removable guards, some solutions do not require the operator to lower the cab to the forage harvester's working position for the time of its disassembly.

Table 1. Transport protection of the shear units of mobile forage harvesters [39–40]

Model	Description
 <p>Claas</p>	<p>As part of its Claas Orbis series of headers, the company offers solutions for transport on public roads. For the Orbis 600, 600 SD and 750 models, the manufacturer offers transport protection in the form of manually folded elements mounted on the front and sides of the device. On the front element, there are red and white markings, position lights and turn signals. Fabric covers with red and white markings are installed on the sides of the working unit. It takes 25 seconds to unfold the Orbis 900 without transport protection, and 30 seconds with it. The transport protection structure consists of a central main part made of a material with red and white warning markings and position lights, as well as two side sections with red and white warning markings. The side guards fold in parallel with the unfolding of the working tool, then, with the help of a hydraulic system and a special hinge, the main front curtain is folded, which rests on the intake channel during the operation of the machine forage harvester [38].</p>
 <p>Krone EasyCollect</p>	<p>It is a two-part device, both parts of which are positioned vertically in the transport position, significantly simplifying the design of the unfolding system. In this model, the transport protection is a structure that attaches directly to the device's frame. The safety structure is equipped with a centrally positioned front support wheel, designed to take some of the weight of the accessory. This arrangement significantly relieves the front axle of the forage harvester. The transport protection in this solution is detached during the machine's operation [39].</p>
 <p>Krone XCollect</p>	<p>It is a three-piece device available in working widths of 6 m, 7.50 m, and 9 m. However, because the working device's design and folding into the transport position differ, it has a different structure. Krone used a two-piece frame in the XCollect model. The side panels have additional elements that, when unfolded, overlap the header's front. Similar to the EasyCollect or the competing Class Orbis, the Krone XCollect is equipped with a foldable, integrated transport chassis that relieves the front axle of the forage harvester when driving on public roads [39].</p>
 <p>Kemper</p>	<p>Kemper shearing units with designations 345pro and 360pro are equipped with transport guards as standard, along with position lights and turn signals. The company's flagship product for moving machines on the road is the Komfort chassis, which can be used with Kemper harvesting units. The manufacturer has designed a separate transport guard that remains completely detached from the shearing tool during work. The chassis is fully automated, and the light connector has been specially designed so that the operator does not have to leave the cab to connect to the forage harvester installation [40].</p>

2.2. Solutions dedicated to grain maize harvesting attachments

The grain corn harvester is a work unit attached to the combine harvester, whose purpose is to pick corn cobs from the plant and deliver them to the threshing and cleaning unit for further processing (grain extraction). It has special units that pull in the plant stem, tear off the cob, direct it to the combine harvester's threshing system, and shred the remaining stem, facilitating the plant's decomposition. The attachment (header) is built as a row device, so the number of connected collecting units determines the number of harvested rows of plants and, thus, the working width of the entire attachment for harvesting maize for grain [9].

Claas implemented a dedicated solution, developing a grain maize harvester called Rovio 4 to replace the older Corio design. As in the previous solution, the Rovio 4 has a transport protection (transport cover) in the form of a front strip with red and white warning markings, position lights and turn signals (Fig. 1).



Fig. 1. Claas Corio with transport protection fitted [38]

On the right and left side of the header there are two tarpaulins to cover the working elements. The entire structure is dismantled by hand. For this solution, the front separation teeth of the header must be folded into the transport position

3. Research methodology

3.1. Aim of the study

The main objective of the work was to develop a concept and design for a transport cover for a grain corn harvesting attachment, which will directly affect the safety of the self-propelled machine's movement on public roads. When starting the design work, several guidelines were adopted. The most important of them are written below:

- the developed solution should be characterized by a light and simple structure
- should be easy to install
- simplicity of operation is required, limiting the combine operator's involvement to the minimum necessary.

The proposed cover must also meet the requirements of the traffic regulations for vehicle protection systems on public roads.

3.2. Scope of research and development work

In the work, a four-stage research procedure was used, as illustrated in Table 2.

Table 2. Scheme of the study procedure

No. (Z)	Research activities – catalogue of works
Z1	Development of a transport security concept for a grain corn harvesting attachment
Z2	Obtaining a dimensional base for the designed cover by dimensioning the existing corn harvesting attachment
Z3	Creating a model of a dimensional base (snap-in) in CAD
Z4	Development of a model of transport security in a CAD computer program, taking into account key elements for designed transport cover
Z5	Analysis of parameters and selection of materials and elements envisaged for the production of the cover
Z6	Development of the structural design of the transport cover for the grain corn harvesting attachment, for the combine harvester
Z7	Development of an electrical harness diagram for road lighting mounted on cover elements
Z8	Preparation of construction documentation of a designed transport cover for a grain corn harvesting attachment for a combine harvester grain

3.3. Research tools and resources

Each stage of the project will be based on a corresponding method. The models of the corn attachment and the transport cover will be created using 3D modeling in the CAD program Autodesk AutoCAD. To design the structure, perform stress analyses and create technical drawings, the INVENTOR PROFESSIONAL software, also part of CAD programs, was used. In addition, the DFMA (Design for Manufacture and Assembly) method will be used in the design of the transport cover, through the use of standardized steel elements that facilitate their acquisition and thus reduce the time required to build the structure. The analysis of warning elements (red and white markings, lights) will be performed using the Delphic method, a heuristic method [6, 14].

4. Implementation of research work

4.1. Transport cover concept for grain maize harvesting attachment – starting point

Taking into account the adopted design assumptions and the developed review of the design of similar devices, when developing the concept of the transport cover for the grain corn harvesting attachment mounted to combine harvesters, it was decided to follow the solutions of Kemper and Krone. In the analysed solutions, the covers are a separate structure, removable during the machine's operation. Such a solution does not require significant interference in the structure of the harvesting unit and does not force the use of complicated mechanisms for folding and unfolding the cover. As a result, removing the cover for the duration of the main machine also prevents the combine from being burdened with additional weight during field operation.

4.2. Conceptual model of transport cover for grain corn harvesting attachment

The conceptual model of the transport cover (Fig. 2) accounts for the adopted design assumptions and the requirements set out in the road traffic law and the relevant act [36].

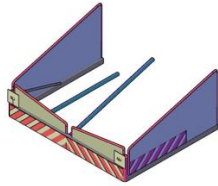

Fig. 2. Conceptual model of transport cover for grain corn harvesting attachment (folded)

The design under development is intended to cover the elements located at the front and sides of the harvesting unit. The front part of the cover is also designed to protect other road users from large, protruding crop dividers, which could, for example, cause punctures to the vehicle body during a collision. To meet the conditions for appropriate marking of elements protruding beyond the vehicle outline, alternating white and red stripes have been applied to the transport cover. They are intended to warn other road users of potential danger and the need to be extra careful. The main task of the side panels is to cover sharp elements and prevent unauthorized contact by outsiders. To facilitate daily operation of the grain maize harvesting attachment, a simple mechanism for unfolding the side panels is used (Fig. 3). As a result, the operator can carry out checks and maintenance on the harvesting unit without detaching the guard.

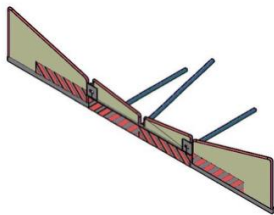

Fig. 3. Conceptual model of transport cover for grain corn harvesting attachment (unfolded)

The foldable structure of the harvesting unit covers the position lights and turn signals of the combine, so it was necessary to fix the lighting elements (lights, combination lamp) in a visible position, in accordance with the provisions of the road law, on the transport cover. It is expected that the cover will protrude more than 1 m beyond the front outline of the vehicle (combine), therefore, in accordance with the provisions of the Act [36], a white light visible from the front of the machine should be used on the front of the guard. The developed cover provides for the use of front combination lamps that meet this legal requirement.

4.3. Grain maize harvesting attachment model

To make models of the grain corn harvesting attachment, a device from the Italian manufacturer Dominoni, model SL 978 [41], was used as a base for construction (Fig. 4).

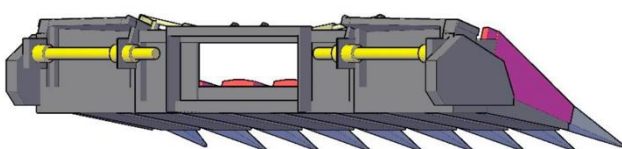

Fig. 4. Model of grain corn harvester attachment (unfolded)

It is an eight-row working unit, which, when folded into the transport position, is 3.25 m wide and weighs 3000 kg (Fig. 5).

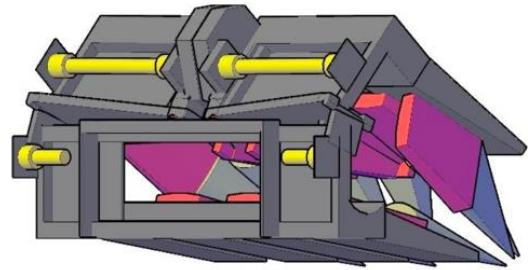

Fig. 5. Model of grain corn harvesting attachment (transport position)

These parameters indicate that, according to the Polish road law, in order for a combine harvester to be able to move with a hitched (aggregated) attachment on public roads, it is necessary to have a permit for vehicles belonging to category I.

The model of the attachment does not fully reflect the real, complete harvesting unit. It was created as a design basis for the transport shield, so it contains only the most important parameters modeled: transport width, length, height, and equipment elements that could interfere with the shield's design. In particular, elements from selected mounting locations of the supporting elements of the cover for the attachment were modeled, for which the aforementioned adjustments to the attachment structure will be necessary.

Dominoni manufactures harvesting units for grain harvesters and field forage harvesters compatible with machines from various manufacturers [41]. For this purpose, it uses specially developed adapters (Fig. 6) so that the design of the harvesting units remains unchanged.

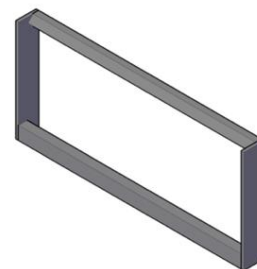

Fig. 6. Adapter Model

During the design of the transport cover, the header adapter was modified to allow the cover to be hooked to the header at the aforementioned three attachment points. The modifications introduced do not interfere with the main structure of the corn harvesting attachment and do not prevent or hinder the aggregation of the harvesting unit with the combine harvester.

4.4. Transport cover model

The transport cover model for the grain corn harvester was based on a conceptual model, matching its components to the Dominoni harvesting unit model (Fig. 7).



Fig. 7. Model of transport cover hooked on the header (unfolded position)

The width of the cover at its widest point in the transport position is 3.46 meters, allowing it to move on public roads with the guard installed after obtaining a category I permit (Fig. 8).

This requirement for this model of attachment stems from its design, with a transport width of more than 3 metres. In accordance with the assumptions also contained in the concept model description, it is envisaged that the side guards are unfolded to the sides. This is a necessary action to hook and detach the cover from the harvesting unit.

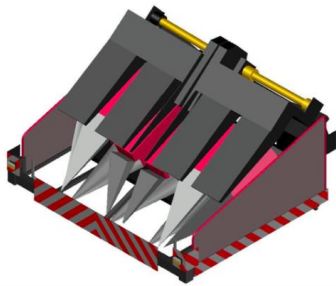

Fig. 8. Model of transport cover hooked on the header (transport position)

In this shield arrangement, the operator gains adequate visibility, allowing him to drive precisely to the guard to attach it. If the side guards are folded and the harvesting unit is folded into the transport position, the operator will not have adequate visibility to drive up to the cover precisely. An additional benefit resulting from such a well-developed design and the rules for its use is the possibility of servicing the corn harvesting attachment (e.g., lubrication, checking the technical condition of components) without the need to detach the cover.

During transport, the side panels are secured to the main frame of the cover with fasteners, preventing them from moving freely.

Subsequently, a dedicated cover mounting system with three connection points was designed, necessitating a slight modification to the header adapter (Fig. 9).



Fig. 9. Adapter model – modified version

The main weight of the cover will rest on the centrally located hook-shaped hook. The lower attachment points of the cover mainly serve a protective and stabilizing function. They have been routed to avoid collisions with the working elements of the harvesting unit, such as the shredder knives. After unfastening it, the cover will be detached by lowering the harvesting unit to the ground and driving the combine backwards.

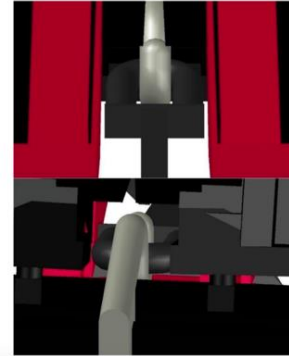

Fig. 10. Top transport cover mount

The modifications to the adapter do not affect the main structure of the harvesting unit. Figure 10 shows that the top attachment of the transport cover does not interfere with the components of the grain corn harvester attachment in the transport position.

4.5. Transport cover design

4.5.1. Input data

Inventor Professional CAD software was used to design the transport cover structure, which allows access to standardized parts and components and is also compliant with Polish Standards. This program also allows you to perform stress analyses of the elements of the structure used for simulations in a static system.

As a result of these analyses, the correctness of the selection of appropriate structural elements and material (grade of structural steel) was verified. During the design, square and round pipes with dimensions in accordance with PN-EN 10219-2 [35] were used. For this standard, unalloyed steels with designations S235JRH, S275J0H, S275J2H, S355J0H, S355J2H and fine-grained steels S275NH, S275NLH, S355NH, S355NLH, S460NH, S460NLH are provided.

The process of selecting the structure's color by comparing visualizations of different colors and their shades was also carried out. To make the warning strips alternately white and red, a self-adhesive prismatic foil was used, which provides additional visibility in adverse conditions and after dusk. The lighting will be provided by an LED combination lamp that includes a turn signal light and a white position light.

4.5.2. Static stress analyses of the cover frame structure

The finite element method (FEM) is a popular technique for solving engineering problems, including structural load analysis, particularly at key structural nodes of the structures under analysis. For this reason, it was used in this research. The basic assumption was to analyze the maxi-

imum allowable loads at key connecting nodes of the developed frame. The following assumptions were taken into account when analyzing the loads on the guard frame:

- Load Type: Loads derived from the weight of the guard material, which is the canvas, and the strength parameters of the structural materials used (steel elements).
- Load Distribution: A load distribution consistent with the structure and operation of the guard components was assumed. The highest loads were assumed on the main crossbeam, the connections between the side frame elements and the crossbeams, and the guard suspension elements on the machine frame.
- Boundary Conditions: The boundary conditions of the structure resulting from the adopted materials and design solutions were determined.
- Materials and Material Properties: The materials and their technical parameters are discussed in section 1 – 4.5.2.

During the design of the shield frame, simulation analyses were performed to assess the structure's von Mises stresses, based on the Huber-Mises-Hencky hypothesis [10]. They are calculated based on the values of the three main stresses, the components' displacements, and the material-specific safety factor. The final design was made of unalloyed steel S235JRH. The dimensions of the profiles used and the dedicated elements are shown in the attached drawings. The first simulation reflects the effect of the Earth's acceleration on the structure. Figure 11 shows the Von Mises stress distribution on the structural elements of the cover frame.

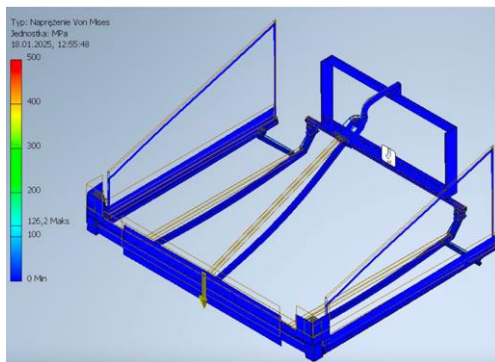

Fig. 11. Von Mises stresses – gravity

During the simulation analyses, welds were also considered, so the maximum stresses, resulting from welding and shear stresses, reached 126.2 MPa. They occur at the junction of two elements. The calculated stress in the structure is in the range of 0 to 50 MPa, with the yield strength at 235 MPa.

Figure 12 shows the factor of safety, which is directly correlated with Von Mises stresses.

The minimum safety factor in deterministic methods is assumed subjectively, based on similar constructions and their applications. Its use is necessary because the mechanical and geometrical features of the structure, the loads acting on the structure, the calculation accuracy and their compliance with the actual operation of the structure may differ from the assumptions of the constructor [7]. It is

assumed that the ratio of critical stress to design working stress should be at least 3.3. On the other hand, Rabotonov [27] proposed reducing this value to 2 [10]. During the design, a minimum coefficient value of 2. This condition has been met. If the stresses resulting from welded joints were excluded, the value of this indicator would be much higher. This effect is suggested by the color corresponding to the safety factor of 5 in the legend.

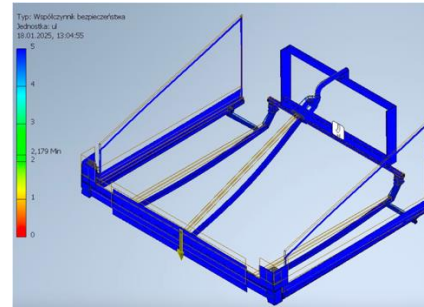

Fig. 12. Safety factor – gravity

Figure 13, on the other hand, shows the way in which the elements of the frame structure move under the influence of the Earth's acceleration.

The transparent skeleton shows the original positions of the elements, while the coloured structure shows their displacements under the influence of the loads acting on them due to gravity. The program, in order to illustrate how elements move, tends to visually exaggerate the displacements. On the other hand, the maximum value on the indicator indicates that the movement of the elements is no more than 0.25 mm.

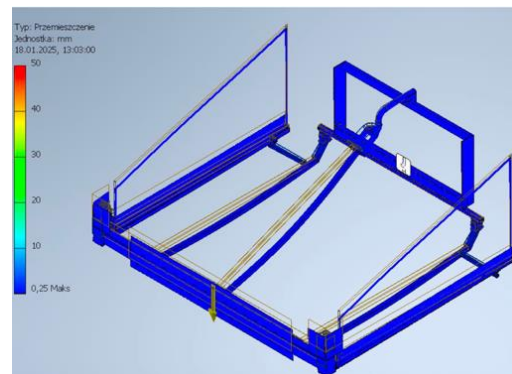

Fig. 13. Displacement of elements – gravity

The results of simulation analyses of the impact of acceleration on the shield structure showed that it is possible to reduce the dimensions of some structural elements to reduce the weight of the transport shield. The high safety index evidences this. However, during a road collision, the transport cover is the first point of contact between the combine harvester and the vehicle, so it was decided not to reduce the dimensions of the selected components.

4.5.3. Physical parameters of the transport shield structure

The transport cover for the grain corn harvester is 3.5 meters wide at its widest point, and the side panels are 2.8

meters long, covering all the working elements of the harvesting unit. The weight of the complete cover structure is 255 kg, which is 8.5% of the grain corn harvesting attachment's weight. Modifications to the adapter that allow the cover to be attached to the attachment elements weigh 36.1 kg. For the research, technical documentation and a list of materials needed for the construction and installation of the cover were prepared.

The assembly diagram of the entire developed transport cover for the grain maize harvesting attachment is shown in Fig. 14.

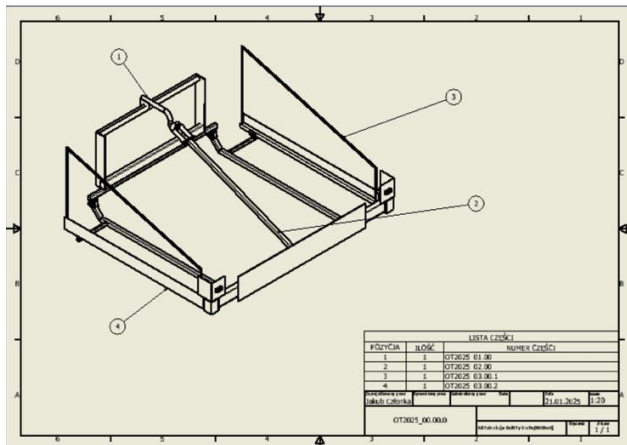

Fig. 14. Assembly diagram of the cover structure

4.5.4. Electrical installation of the cover lighting

The electrical system for the canopy lighting will be based on a standard solution used in agricultural vehicles and machinery. In this case, the combine harvester has an electrical system for an external, specialized trolley to transport the harvesting units, with a socket at the rear. To connect the lighting to the canopy, run an electrical cable with a socket to the front of the combine and mount it in a safe location that does not interfere with the operation of the harvesting units or the processes of disconnecting and connecting the harvesting unit to the combine. The electrical system uses a seven-pin connector, with the following pins corresponding to the following lights (Fig. 15): fog light, left parking light, right parking light, brake light, left turn signal, right turn signal, and ground wire.



Fig. 15. 7 PIN plug [42]

Road traffic regulations require full visibility in front of the vehicle when traveling on public roads, especially in low-visibility conditions. To meet these requirements, the guard elements, in addition to the red and white reflective warning markings, feature two combination lamps on the right and left sides. These lamps are divided into two zones: high beam and turn signal, and are connected detachably

via a cable and plug to the electrical socket on the base machine.

5. Discussion and conclusions

Journeys on public roads of combine harvesters and forage harvesters are currently often carried out at speeds of 40 km·h⁻¹. To increase the vehicle's safety during such journeys on public roads, manufacturers of these machines introduce various additional elements into their designs.

Among them, we can distinguish transport covers, called transport protection by some manufacturers. Slightly older models are not equipped with this type of protective elements, so the work involved developing and constructing a transport cover for attachment to a combine harvester for row-harvested maize [21, 38–41].

By starting the research, the solutions used by transport guards among manufacturers of self-propelled forage harvesters and attachments for grain maize harvesting were analyzed. The methods for marking non-standard vehicles and the legal regulations to be followed for a vehicle with such a cover to move on public roads were verified [36, 37].

Based on the analyses, a conceptual model of a transport cover dedicated to the grain corn harvesting attachment was developed. To develop a model of the cover structure, a dimensional base in the form of a harvesting unit was required, to which the designed cover would be referenced. The existing Dominoni SL 978 harvesting unit [41] was used as a dimensional basis, and a design model was developed that accounts for the most important dimensions.

The conceptual model was adapted to the design base, taking into account the design assumptions, resulting in a model of a transport cover. To mount the cover to the attachment, a dedicated hooking system has been designed. The next step was to make a structure based on the cover model Transport. For this purpose, the Inventor Professional program was used, with which appropriate elements compliant with Polish standards were selected. The material of components (steel grade) was selected based on simulation analyses. Their results showed the potential to reduce the dimensions of the adopted structural elements. Given the importance of the harvester's harvesting unit cover for the road safety of other road users, it was decided to retain the originally selected elements.

Due to the dimensions of the grain maize harvesting attachment and the designed cover, lighting had to be placed on its structure. For this purpose, a diagram of the electrical installation was created. The last stage was the development of the construction documentation of the transport cover for the grain corn harvesting attachment.

Thus, it must be stated that the adopted goal of the work has been fully achieved. In accordance with the adopted assumptions, a simple, lightweight, and easy-to-use cover for the combine harvester unit was developed, more precisely, an attachment for row-harvesting corn for grain by the combine harvester. The designed design meets the requirements for moving on public roads of the main machine (combine). Thus, it increases the safety of the movement of this type of vehicle with harvesting units attached to the front, folded for transport across crossings. The developed cover is designed to combine harvesters that were not factory-equipped with this element, thereby increasing safety

when driving on public roads. Some models of combine harvesters and forage harvesters of large corporations in the industry have dedicated safety solutions of this type. In these cases, transport covers have been included in the structures already at the design stage of the harvesting unit itself, e.g. folding distributors in Claas Rovio 4, automatic folding/detaching of the cover from the level of the operator's cab (Claas, Krone, Kemper), and a dedicated connector for lights in the Kemper Komfort chassis.

While the design of the corn header's transport guard presented in this paper is an important issue, aimed at ensuring efficient and safe harvesting, there are several significant limitations and potential directions for further research:

- Impact of vibrations during transport: During transport, corn headers can experience intense vibrations, which can degrade the guard's durability. Therefore, it is crucial to assess the impact of vibrations on the guard's design and develop technical solutions to reduce vibrations and ensure the guard's stability during transport.
- Guard durability: Another important aspect is the durability of the header's transport guard. It is necessary to test the materials' resistance to weather conditions, mechanical damage, and the intense loads associated with

field work. Possible directions for further research include the use of modern composite materials and structural reinforcement techniques to increase the guard's durability.

- Compatibility with headers of different working widths: Depending on the model and manufacturer of the corn harvesting machine, the headers' working widths may vary. Therefore, it is important to develop a cover design that is universal and compatible with various header widths. Research directions may include developing systems to adjust the cover width and testing their compatibility with various header types.
- Issues related to ergonomic aspects and examining the time required for assembly and disassembly, which are essential for practical usability.

Therefore, further research on the design of the corn header transport cover should focus on reducing vibration-related impacts, increasing durability, and ensuring universality and compatibility across various header widths. The potential for further research in this area is significant, and always aims to improve efficiency and safety. Therefore, these will be the subject of further research by the authors of this study.

Bibliography

- [1] Afify MK, Nada AA, Mechail WM. Selection the proper system of planting and harvesting for rice crop. *Misr J Ag Eng.* 2000;17(2):388-400.
- [2] Andrych-Zalewska M, Chłopek Z, Merkisz J, Pielecha J. Exhaust emission from a vehicle engine operating in dynamic states and conditions corresponding to real driving. *Combustion Engines.* 2019;178(3):99-105. <https://doi.org/10.19206/CE-2019-317>
- [3] Andrych-Zalewska M, Chłopek Z, Merkisz J, Pielecha J. Research on exhaust emissions in dynamic operating states of a combustion engine in a Real Driving Emissions test. *Energies.* 2021;14(18):5684. <https://doi.org/10.3390/en1418>
- [4] Arnaout MA, Abdel-Wahab MK, El-Sharabasy MM. Selecting the proper system for mechanizing grain crops harvesting in the small holdings. *Misr J Ag Eng.* 1998;15(1):133-144.
- [5] Białczyk W, Cudzik A, Czarnecki J. *Ciągniki i pojazdy rolnicze* (in Polish). Oficyna Wydawnicza Atut – Wrocławskie Towarzystwo Oświatowe. Wrocław 2012.
- [6] Cempel C. *Teoria i inżynieria systemów* (in Polish). Wydawnictwo Instytutu Technologii Eksploatacji. Radom 2006.
- [7] Chinsuwa W, Chuan-Udom S, Phayom W. Rice harvest losses assessment. *TSAE Journal.* 2002;9(1):14-19.
- [8] Chinsuwa W, Pongjan N, Chuan-Udom S, Phayom W. Effects of threshing bar inclination and clearance between concave rods on performance of axial flow rice thresher. *TSAE Journal.* 2003;10(1):25-30.
- [9] Członka J. Transport cover design for grain corn harvesting attachment. Engineering work carried out under the supervision of F. Adamczyk at the Department of Biosystems Engineering at the Poznan University of Life Sciences, Poznan 2025.
- [10] Dietrich M, Kocańda S, Korytkowski B, Ozimowski W, Stupnicki J, Szopa T. *Podstawy konstrukcji maszyn* (in Polish). WNT. Warsaw 1995.
- [11] Dreszer K, Pawłowski T, Szczepaniak J, Szymanek M, Tanaś W. *Maszyny rolnicze* (in Polish). Wydawnictwo PIMR. Poznań 2015.
- [12] Ghonimy MI, Rostom MN. Tech-economical approach to combine harvesters evaluation. *Misr J Ag Eng.* 2002;19(1):83-99.
- [13] Hossain M, Hoque M, Wohab M, Miah, MM, Hassan M. Technical and economic performance of combine harvester in farmers field. *Bangladesh Journal of Agricultural Research.* 2015;40:291-304.
- [14] Jaros M, Pabis S. *Inżynieria systemów* (in Polish). Wydawnictwo SGGW. Warsaw 2007.
- [15] Kamaruzaman J, Roy SK, Ismail WIW, Ahmad D. Performance evaluation of a combine harvester in Malaysian paddy field. Institute of Bioscience, Faculty of Engineering, Universiti Putra, Malaysia 2001.
- [16] Kuboń M. Possession and utilization of transport facilities in farms engaged in various agricultural production types. *Inżynieria Rolnicza.* 2007;8(96):141-148.
- [17] Łubiński M, Filipowicz A, Żółtowski W. *Konstrukcje metalowe. Cz. 1. Podstawy projektowania* (in Polish). Wydawnictwo „Arkady”. Warsaw 2000.
- [18] Mahrouf ARM, Rafeek MIM. Mechanization of paddy harvesting: an economic perspective. Socio Economic and planning center. Peradeniya. Sri Lanka 2010.

- [19] Merkisz J, Pielecha J, Jasiński R. Analiza parametrów operacyjnych silnika i emisji spalin ciągnika rolniczego podczas pracy na hamowni (in Polish). WUT J Trans. Eng. 2017;115:145-159.
- [20] Merkisz J. Tendencje rozwojowe silników spalinych maszyn i agregatów rolniczych (in Polish). Technika Rolna Ogrodnicza Leśna. 2010;2:4-9.
- [21] Mieszkalski L. Metodyka projektowania narzędzi i maszyn rolniczych w zarysie (in Polish). Wydawnictwo ART. Olsztyn 1995.
- [22] Mirzazade A, Shamsollah A, Asghar M. Intelligent modeling of material separation and combine harvester's thresher by ANN. Intl J Agri Crop Sci. 2012; 4(23):1767-1777.
- [23] Miu P. Combine harvesters theory, modeling, and design. CRC Press Taylor & Francis Group. New York 2016.
- [24] Omran MS. A comparative study of the most widely harvesting system for wheat crop in Egipt. Misr J Ag Eng. 2007;25(3):804-823.
- [25] Owsiak Z, Lejman K. Maszyny rolnicze (in Polish). Wydawnictwo ATUT. Wrocław 2012.
- [26] Pishgar-Komleh SH, Keyhani A, Sarkari MRM, Jafari A. Assessment and determination of seed corn combine harvesting losses and energy consumption. Elixir Agriculture. 2013;54:12631-12637.
- [27] Rabotnov YN, Leckie FA, Prager W. Creep problems in structural members. J Appl Mech. 1970;37(1). <https://doi.org/10.1115/1.3408479>
- [28] Sikora M, Orliński P. Hydrotreated vegetable oil fuel within the Fit for 55 package. Combustion Engines. 2024;197(2):3-8. <https://doi.org/10.19206/CE-174554>
- [29] Skrobaccki A, Ekielski A. Pojazdy i ciągniki rolnicze (in Polish). Wydawnictwo „Więś Jutra”. Warsaw 2012.
- [30] Špokas L, Adamčuk V, Bulgakov V, Nozdrovický L. Te experimental research of combine harvesters. Res Agr Eng. 2016;62:106-112.
- [31] Špokas L, Steponavičius D, Wacker P. Besonderheiten der Dinkelernte und des Ausdruschprozesses bei Dinkel. Tagungsband VDI-MEG-Kolloquium Landtechnik. Mähdrescher H. 2005;38:95-102.
- [32] Špokas L. Influence of technological parameters of combine harvester “NEW HOLLAND” to grain macro damage. IAg Eng LUA&LU of Ag. 2006;38:27-41.
- [33] Stępień Z. Ammonia as an alternative fuel to internal combustion engines. Combustion Engines. 2025; 200(1):117-127. <https://doi.org/10.19206/CE-200289>
- [34] Ye Y, Liu X, Lin J, Chang J, Chen Y. Design of hydrostatic drive system for corn combine harvester, Agricultural Machinery Usage & Maintenance, 2016; 7:13-14.
- [35] PN-EN 10219-2:2019-07. Cold Welded Seam Sections from Structural Steels – Part 2: Tolerances, Dimensions and Static Quantities.
- [36] Regulation of the Minister of Infrastructure of 31 December 2002 on the technical conditions of vehicles and the scope of their necessary equipment (Journal of Laws 2024.502 par.45 sec. 3 point 1).
- [37] Road Traffic Law (Journal of Laws 2024.1251 art. 64b), (Journal of Laws of 1997 No. 98 item 602 Appendix 1).
- [38] www.claas.com.pl (Claas company website).
- [39] www.krone-agriculture.com (Krone company website).
- [40] www.kemper-stadtlohn.de (Kemper company website).
- [41] www.dominoni.com (Dominoni company website).
- [42] www.agrorami.pl

Przemysław Niewiadomski, DSc, DEng., Prof. UPP – Faculty of Environmental Engineering and Mechanical Engineering, Poznan University of Life Sciences, Poland.

e-mail: przemyslaw.niewiadomski@up.poznan.pl



Florian Adamczyk, DSc., DEng., Prof. UPP – Faculty of Environmental Engineering and Mechanical Engineering, Poznan University of Life Sciences, Poland.

e-mail: florian.adamczyk@up.poznan.pl



Jakub Członka, Eng. – Faculty of Environmental Engineering and Mechanical Engineering, Poznan University of Life Sciences, Poland.

e-mail: 86330@student.up.poznan.pl

